

BULK PACKER (LS-132)

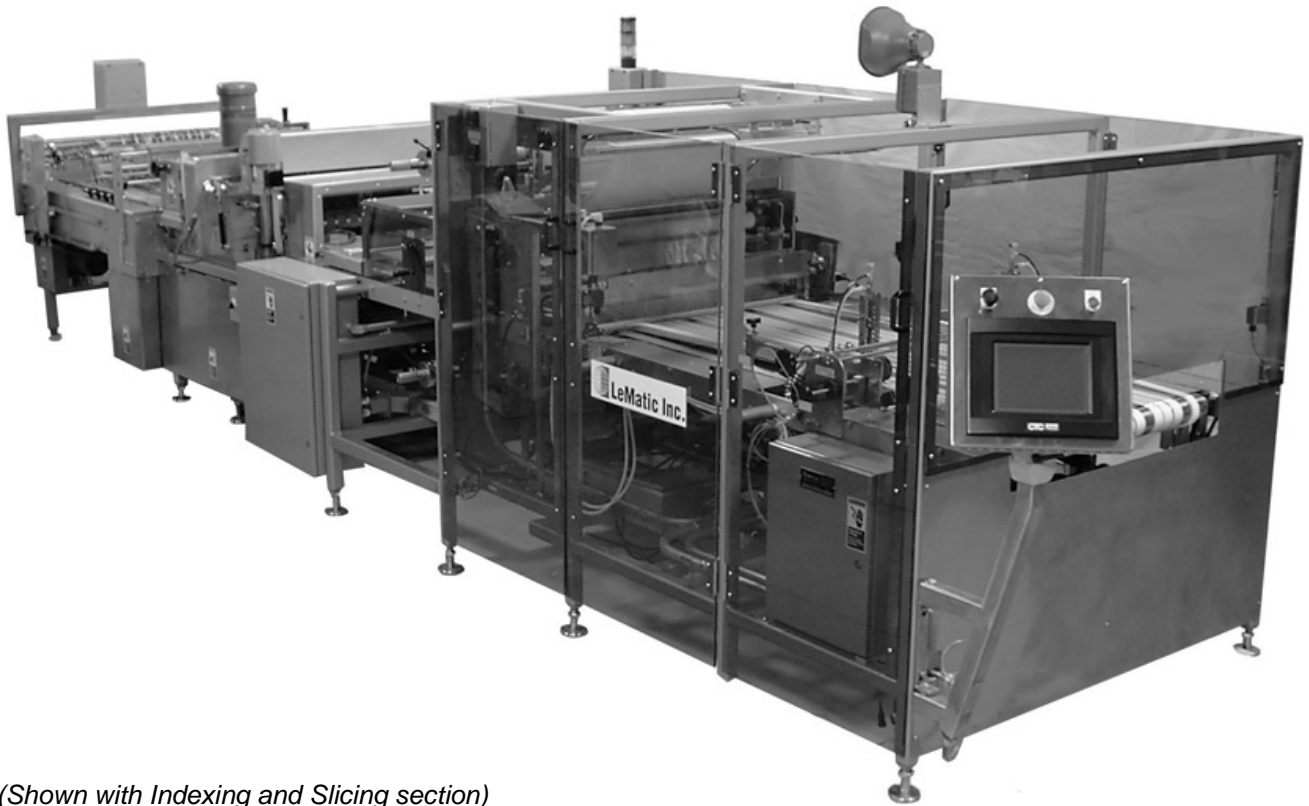

(Shown with Indexing and Slicing section)

Features

- Exclusive Hand-Wheel Adjustable Lane Guide System makes changeover quick and easy
- Moving Side Belts, “On the Fly” Moving Regouper, and Package Vacuum System assure a consistent and tight package
- Advanced microprocessor control
- Advanced timing and control abilities are available to service or maintenance personnel via password protected control software
- Slide-out and removable Sealing Bar Assembly for ease of maintenance
- Timing Belt Drive System
- Enclosed Air Supply System
- Design emphasizes safety and reliability, straight forward operation and complete accessibility for maintenance and sanitation

BULK PACKER

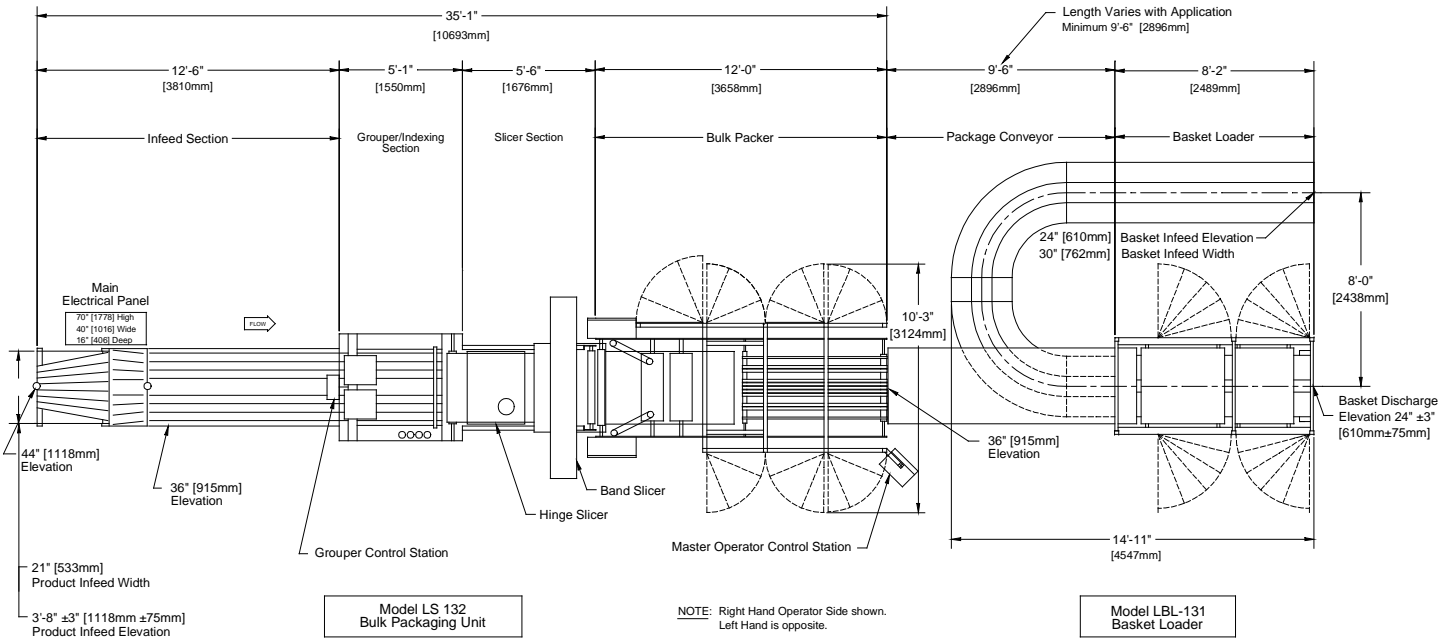

General Specifications

- Production Rate: Maximum of 30 packages per minute.
- Product Size: Maximum 27" [686mm] wide, 3 1/2" [90mm] high
- Film Width: Maximum 33" [838mm] Minimum 28" [711mm]
- Electrical Power: 34 KW, 3 Phase, various Voltages Available
- Air Requirements: 24 CFM [680 L/M] @ 90 PSI [6.2bar]
- Maximum Elevation: 6' 6" ±3" [1981 ±75mm] at Bulk Packer Section

Options

- Single Center Seal
- Dual Center Seal & Cut
- Up to 12 Lane Guides
- Hinge, Web, Single or Double through slice, and New England Top Slice

 **LeMatic Inc.**
Performance you can depend on...
Quality you can believe in.

2410 W. Main Street
Jackson MI 49203 USA
Phone (517) 787-3301
Fax (517) 782-1033
www.lematic.com