

DRY BUN PAN CLEANER (BM100303 / BM100305 / BM100307 / BM100309)

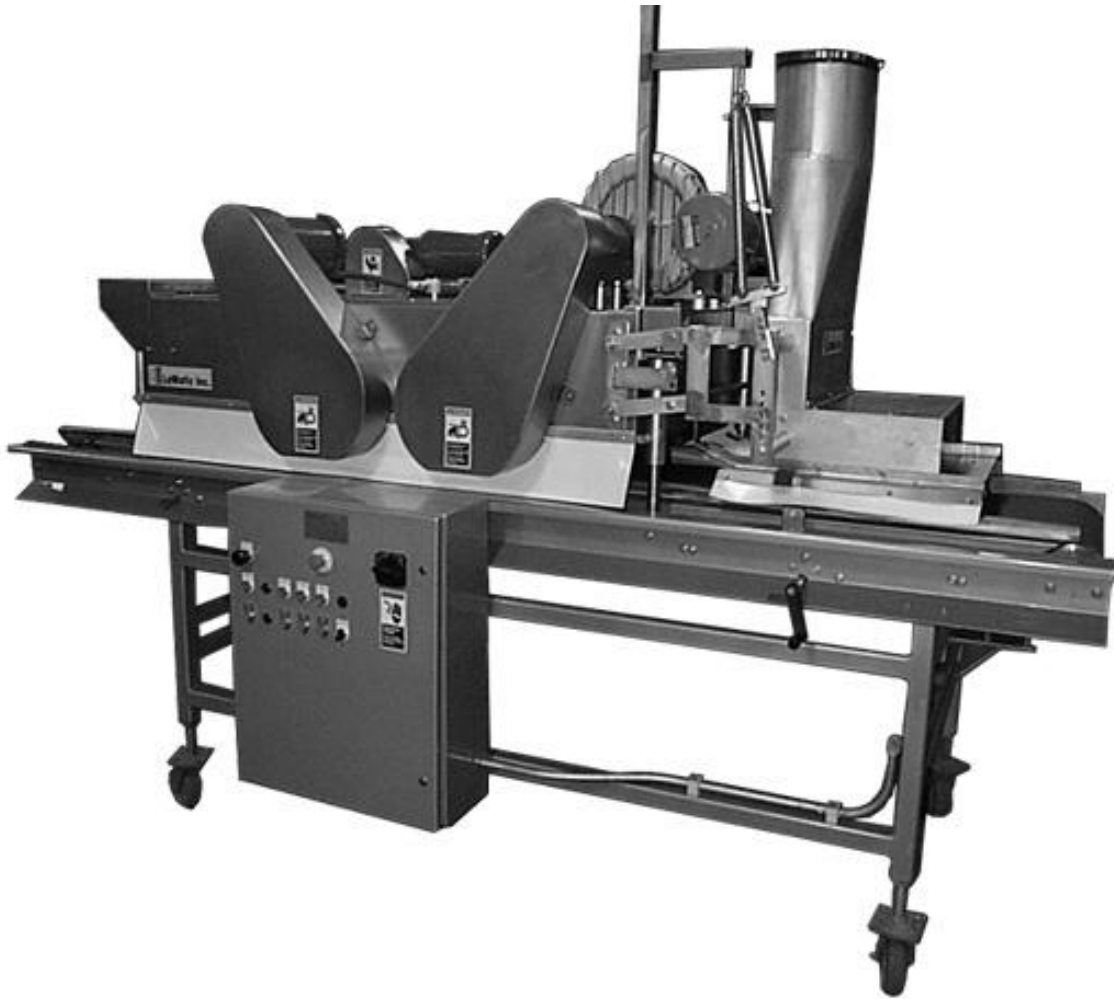

Features

- Two stage brushing action aggressively loosens debris from pan top and sides
- Counterbalanced Air/Vacuum Head uses dual actions of regenerative air, and vacuum to air blast and vacuum the pan free of debris
- Regenerative Blower and Debris Collection Vacuum System included
- Flexible design allows mounting on customers conveyor, optional LeMatic Floor Standing Conveyor (Level or, Inclined), or optional LeMatic Overhead Support Conveyor
- Gearmotor driven Power Lift eliminates the need for compressed air lines and cylinder replacement.

DRY BUN PAN CLEANER

Dimensions

	BM100303	BM100305	BM100307	BM100309
A= Conveyor Belt Width	22" [559mm]	26" [660mm]	36" [914mm]	40" [1016mm]
B= Brush Width	24" [610mm]	30" [762mm]	38" [965mm]	40" [1016mm]
C= Cabinet Width	34" [864mm]	40" [1016mm]	46" [1168mm]	50" [1270mm]
D= Inside Frame Width	34" [864mm]	40" [1016mm]	46" [1168mm]	52" [1321mm]
E= Outside Frame Width	41" [1041mm]	47" [1194mm]	53" [1346mm]	59" [1498mm]

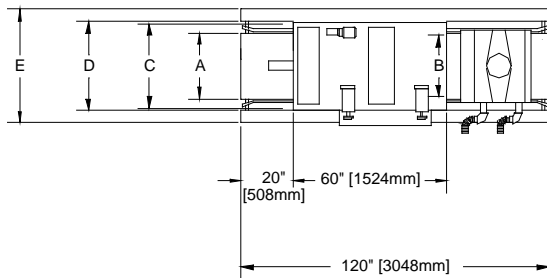

Rigid ductwork from vacuum unit to recommended attachment at pan cleaner. (by customer)

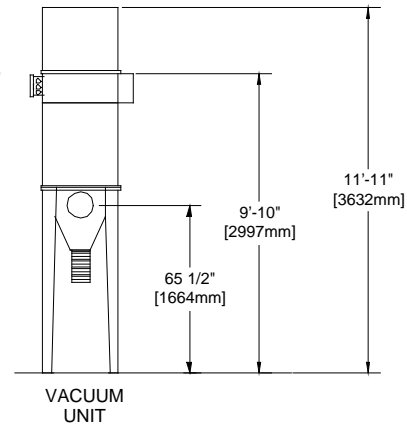
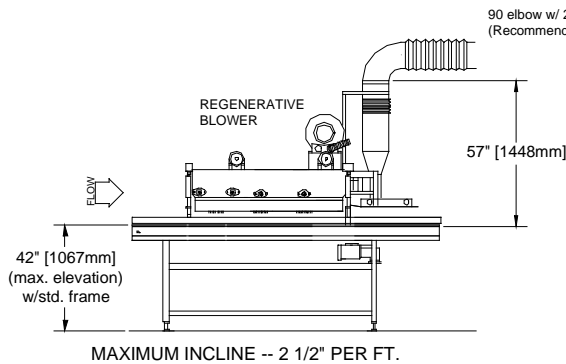
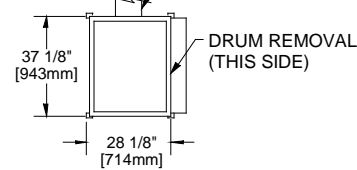

General Specifications

- Maximum Conveyor Speed: 100ft./min [30.5M/min]
- Electrical Controls: 208-230-460 Volt 60 Hz 3 Ph (Other Voltages Available)
- Control Voltage: 24VDC (Other Voltages Available)
- Air Requirements: 1" NPT(min. 3/4" NPT) Air Line w/ Filter & Regulator
18 CFM @ 90 PSI
- Connected Load: 15 to 19KVA

Options

- Stainless Steel construction
- Metric requirements
- Wash Down Construction
- Special Voltage
- Variable Speed Brushes
- Conveyor Options:
 - Pan Bottom Cleaning Assembly
 - Incline or Specialty conveyor designs
 - Floor Standing or Overhead Support Configurations



LeMatic Inc.

*Performance you can depend on...
Quality you can believe in.*

2410 W. Main Street
Jackson MI 49203 USA
Phone (517) 787-3301
Fax (517) 782-1033
www.lematic.com