

## BAGEL SLICER (GU20-6B9)



### Features

- Completely adjustable for slicing height, slicing depth and top conveyor pressure
- Durable construction coupled with safety conscious design
- Heavy duty drives and drive components to handle even the toughest bagels
- Patented Loc-Cap Design insures a secure hold on slicing blades, while allowing fast and easy change out
- Power head lift is standard
- Utilizes Web slicing for easy pull apart of product by customer

# BAGEL SLICER

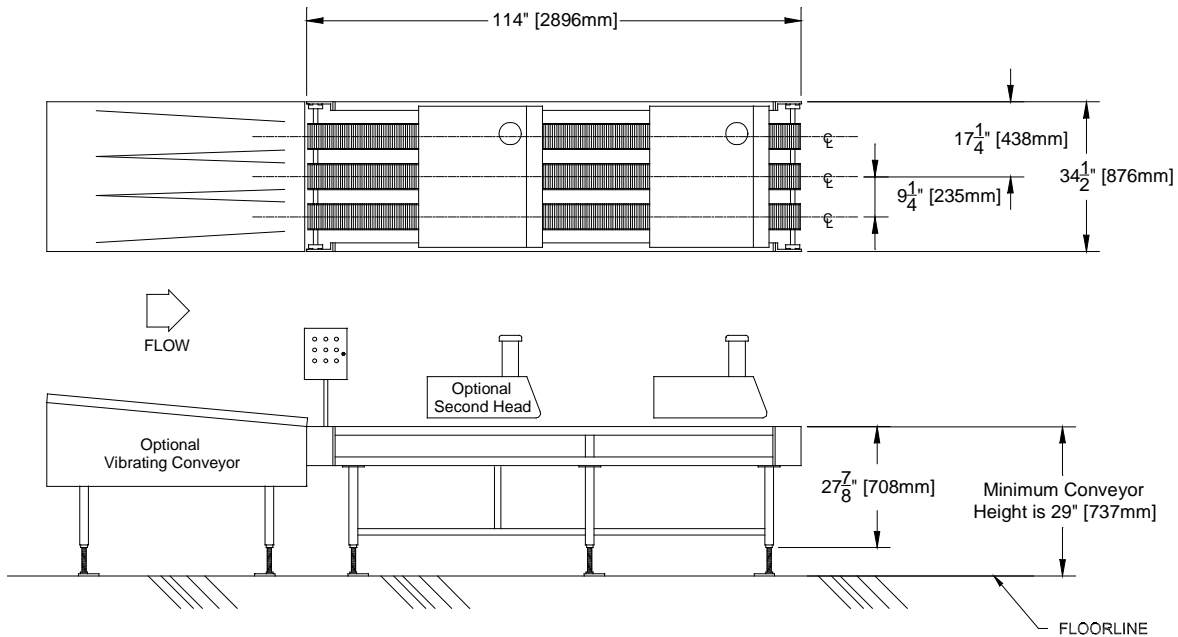

## General Specifications

- Production Rate: 24,000 bagels per hour
- Conveyor Speed:
- Electrical Controls: 208-230-460 Volt 60 Hz 3 Ph (Other Voltages Available)
- Control Voltage: 24VDC
- Air Requirements: None
- Slicer Head Drive: 3HP w/Brake
- Connected Load: 6.5KVA

## Options

- Variable Speed Drive
- Washdown construction
- Optional second Slicing Head to enable continuous non-stop production
- Flip Down Bagelette guides to run bagels and bagelettes on the same slicing line

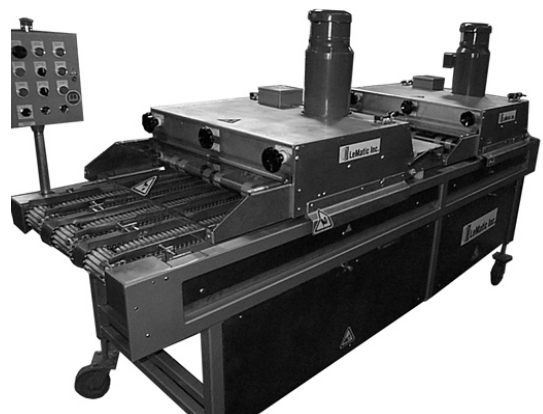

 **LeMatic Inc.**  
*Performance you can depend on...*  
*Quality you can believe in.*

2410 W. Main Street  
Jackson MI 49203 USA  
Phone (517) 787-3301  
Fax (517) 782-1033  
[www.lematic.com](http://www.lematic.com)